

Bringing Renewable Energy to the Electrical Engineering Undergraduate Education and Research at UPRM

Eduardo I. Ortiz-Rivera, Jesus Gonzalez-Llorente, and Andres Salazar-Llinas
 University of Puerto Rico at Mayagüez, jesus.gonzalez@ece.uprm.edu, andres.salazar@ece.uprm.edu,
eduardo.ortiz@ece.uprm.edu

Abstract - The development of systems implementing renewable energy sources is essential to society's evolution and survival. Currently the major source for electric energy is the burning of fossil fuels; thus, it is a problem because of two reasons: it increases the emission of harmful gases to our atmosphere and it is an energy source that will not last forever. In our present time the amount of energy produced by a single renewable source is considerably smaller than the amount produced by the burning of fossil fuels. Therefore, it is necessary to develop energy systems that will use various types of renewable energy in parallel, all contributing to a large complex system. It is the purpose of this paper to attract undergraduate students to the area of renewable energy by bringing them with a research experience. The student had the experience to study three alternative sources: photovoltaic systems, fuel cells, and thermoelectric generators. The student had the opportunity to use electrical models describing the performance of each renewable source. The mathematical models were developed by the mentor in different software like Matlab, Saber, P-Spice, and Simulink. Circuit analysis, simulations and experiments are presented in the paper.

Index Terms – Behavioral models, Mentoring, Renewable energy simulation, Undergraduate research.

INTRODUCTION

The greenhouse gases such as carbon dioxide absorb the infrared radiation and trap the heat in the Earth's atmosphere. These greenhouse gases emissions come primarily from the combustion of fossil fuels in energy use. In the United States, fossil fuels supply 85 percent of the primary energy consumed and are responsible for 98 percent of emissions of carbon oxide; the electricity generation consumes 40 percent of U.S. primary energy [1].

The impact of the traditional fossil fuels in our environment and the fact that these are non-renewable sources, have encouraged the need to find alternative energy sources to the fossil fuels. Therefore, the renewable energy sources have been one of the most important topics of research in the last years. They are constantly replenished and will never run out [2].

Among renewable energy sources, this work focuses on solar energy using photovoltaic (PV) panels, and hydrogen by means of fuel cells (FC). In addition the thermoelectric generator (TEG) is also considered, which based on the Seebeck effect, converts the heat or temperature gradient into electrical energy [3].

The photovoltaic panel or photovoltaic module (PVM), the fuel cell and the thermoelectric generator have been modeled using mathematical behavioral models. These models describe the electrical characteristics of each one based on the power, current, voltage and temperature relationship.

The behavioral models used in this work emulate the typical shape of the electrical characteristics for different renewable energy sources; therefore, these are suitable for circuit analysis and simulation at the academic level during undergraduate research experiences. With these experiences undergraduate students can improve their conceptual understanding, including vocabulary, as well as, improve attitudes towards research on renewable energy [4].

The growth in the undergraduate research works at University of Puerto Rico at Mayaguez (UPRM) had been motivated by the faculty members of the Department of Electrical and Computer Engineering [5],[6]. With this work the undergraduate students are exposed to renewable energy sources, creating in them the interest about the new technologies, and involving the undergraduate student with typical software used in the industry such as Saber, P-Spice and Matlab/Simulink. Formerly, undergraduate research experience for student without previous knowledge of the area of power electronics have been executed [6], in that experience the student was in charge of analyze the Z-source converter.

The paper is divided in five sections as is described in the next lines. Section II presents the mathematical models that describe the behavior of each renewable energy source studied. This section also describes the way that the mathematical models were implemented and comparisons of real data and simulation are presented. Section III gives a detailed explanation of several systems with renewable energy sources used as examples. Next sections present the experience assessment and the conclusions of this work.

SIMULATION OF RENEWABLE ENERGY SOURCES

I. Thermoelectric generator

The used electrical TEG mathematical model considers the boundary conditions and shape of the TEG P - V curve. The power, P , and the voltage, V , can be obtained by (1) and (2) respectively. The variables V_x , I_x , and P_{max} are the open-circuit voltage, short-circuit current, and maximum power for the TEG at a given cooling water temperature, T .

$$P=I \cdot V=V_x-I \cdot V_x \cdot I^2/I_x \quad \forall V \in [0, V_x], P \in [0, P_{max}] \quad (1)$$

$$V=V_x - V_x \cdot I/I_x \quad (2)$$

The model given by (2) describes a linear equation whose slope and the constant term are equal to $-V_x/I_x$ and V_x respectively. This equation is suitable both for circuit analysis and for integration of renewable sources to undergraduate courses.

In Simulink, the model given by (2) was developed as is shown in Fig. 2. The data to verify the proposed TEG model was obtained from the paper written by Chu *et al.* [9]; the open voltage and the maximum current are $V_x = 17.5V$ and $I_x = 12A$ respectively. Fig. 2 shows the V - I and P - I characteristics using the proposed TEG Model. These results are very similar to the results provided in [9].

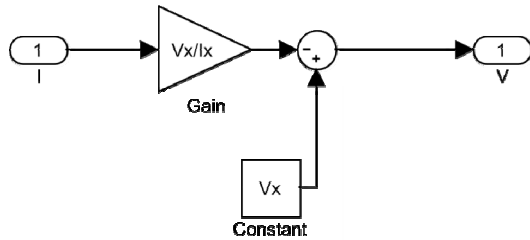

FIGURE 1 SIMULINK TEG BLOCK.

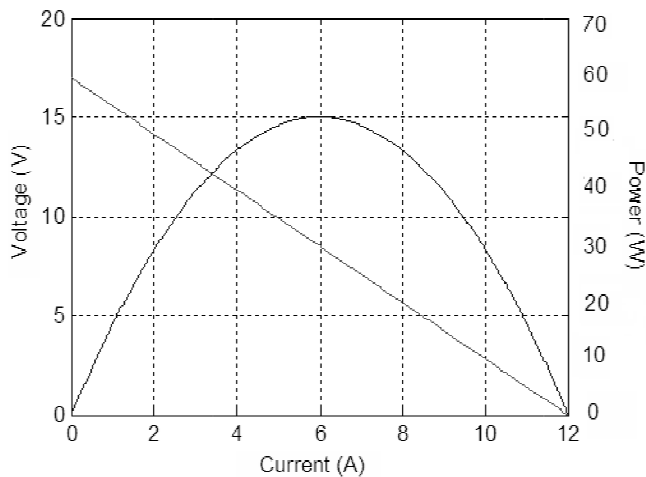

FIGURE 2 PROPOSED TEG MODEL AT 318K.

II. Photovoltaic generator

The photovoltaic module model used in this paper was proposed in [7]. The relationship between the current (I) and the voltage (V), for any PVM is given by (3). This model takes into consideration the short-circuit current (I_x) and the open-circuit voltage (V_x) at any given irradiance level (E_i) and temperature (T), and the PVM characteristic constant (b).

$$I(V)=[I_x/(1-\exp(-1/b))]\cdot[1-\exp(V/(b \cdot V_x)-1/b)] \quad (3)$$

For the exponential model in (3), the constant b is the only one that needs to be calculated. This is computed using an algorithm based on the Fixed Point Theorem shown in (4), where ξ is the maximum permitted error; V_{oc} and I_{sc} are the open-circuit voltage and the short-circuit current at Standard Test Condition (STC); V_{op} and I_{op} are the optimal voltage and the optimal current at STC.

$$\text{while } |b_{n+1} - b_n| > \xi$$

$$b_{n+1} = \frac{V_{op} - V_{oc}}{V_{oc} \cdot \ln \left[1 - \frac{I_{op}}{I_{sc}} \cdot \left(1 - \exp \frac{1}{b_n} \right) \right]} \quad (4)$$

The PVM model given by (3) was developed in Saber, Spice and Simulink[10]. These implementations are suitable for analyzing the PVM characteristics, as well as, being appropriate to analyze a photovoltaic system in simulation. Fig. 3 shows the scheme implemented in Saber to obtain the PVM characteristic curves; the resistor connected to the PVM increases from 1.0mΩ to 5.0kΩ; then, the simulation is repeated for different irradiance values. The PVM output current vs. PVM output voltage, and also the PVM power vs. PVM voltage are shown in Fig. 4.

In addition, using a pyranometer and a DC electronic load real data were obtained. Fig. 5 shows the measured data and the calculated data using the model described previously.

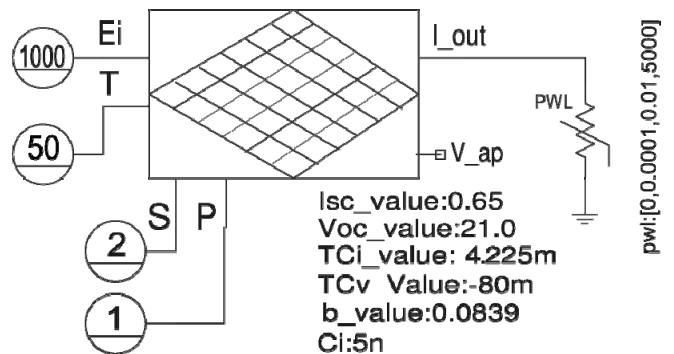

FIGURE 3 SABER SCHEMATIC DIAGRAM.

III. Fuel cells

A fuel cell behavioral model was proposed in [8]. This electrical model considers the boundary conditions and shape of the fuel cell V - I curve as given in [8]. The variables V , and I are the voltage, and current for a fuel cell with units in volts and amperes. I_H , V_H and V_L are the high current, the high voltage and low voltage for a fuel cell. V_H can be obtained when the current is zero. V_L can be obtained when the current is I_H . The range of existence of I will be from 0 to I_H and the range of existence of $V(I)$ will be from V_L to V_H . The fuel cell can be described in terms of the values obtained by the fuel cell V - I and P - I curves using either (5) or (6).

$$V = V_L + (V_H - V_L) [\arccos(2I/I_H - 1)/\pi]^k \quad (5)$$

$$P = V_L I + I(V_H - V_L) [\arccos(2I/I_H - 1)/\pi]^k \quad (6)$$

The variable k is the characteristic constant for the fuel cell based on the V - I and P - I curves given in [8]. P_{max} and I_{op} are the maximum power, and the optimal current to obtain the maximum power for a fuel cell.

$$k = \ln[(P_{max} - I_{op} V_L) / (I_{op} V_H - I_{op} V_L)] \cdot \ln[\arccos(2I_{op}/I_H - 1)/\pi]^{-1} \quad (7)$$

Using Matlab and the behavioral mathematical model given in (5), the V - I and the P - I relationship are calculated for a H-100 by Horizon fuel cell technologies. These relationships are shown in Fig. 6, and they are very similar to presented in the product datasheet.

EXAMPLES OF APPLICATION

I. Thermoelectric generator feeding a DC motor

State space modeling can be used to model a permanent magnet direct current (PMDC) motor directly coupling to a TEG. This configuration is shown in Fig. 7. A differential equation can be derived by using Kirchoff's electrical voltage law around the electrical loop; this equation is given by (8), where R_a , L_a and K_e are: the armature resistance; the armature inductance; and the back emf constant, respectively.

$$R_a \cdot i_a + L_a \cdot di_a/dt + K_e \cdot \omega_m = V_x - V_x/I_x \cdot i_a \quad (8)$$

The sum of DC motor torques must be equal to zero; hence, the DC motor torque balance equation is given by (9), where J , B_m , and T_L are: the moment of inertia of the motor and connected load; the constant viscous friction coefficient; and the load torque, respectively.

$$K_e \cdot i_a = J d\omega_m/dt + B_m \cdot \omega_m + T_L \quad (9)$$

From (8) and (9) the state space model of the system, for armature current and angular speed, can be written as:

$$d i_a/dt = -R_a/L_a \cdot i_a - V_x/I_x \cdot L_a \cdot i_a - K_e/L_a \cdot \omega_m + V_x/L_a \quad (10)$$

$$d\omega_m/dt = -B_m/J \cdot \omega_m + K_e/J \cdot i_a - T_L/J \quad (11)$$

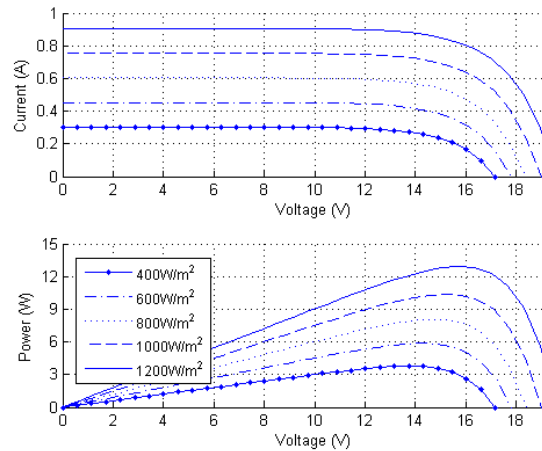

FIGURE 4 PVM CHARACTERISTICS CURVES AT DIFFERENT IRRADIANCE AND T=50°C.

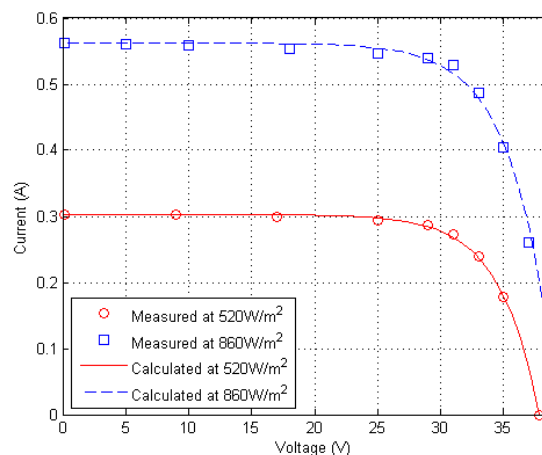

FIGURE 5 I-V CHARACTERISTICS OF PVM SX-10M

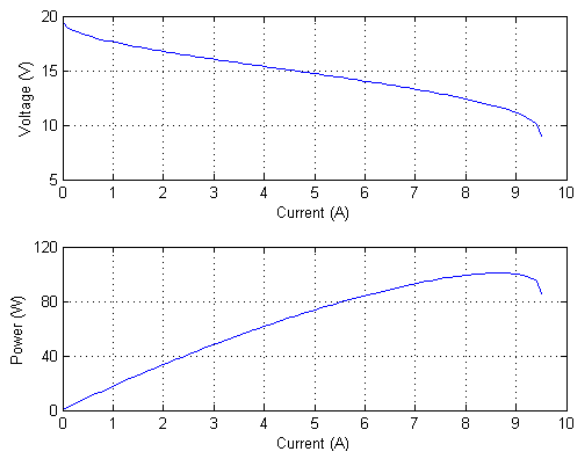

FIGURE 6 CHARACTERISTICS CURVES OF FUEL CELLS H-100 BY HORIZON FUEL CELL TECHNOLOGIES

The simulated model is shown in Fig. 8. The TEG model is simulated based on (2) and the TEG characteristic are shown in Fig. 2. The simulated PMDC motor is based on (8) and (9). This motor has the following parameters: $R_a = 8.57\Omega$, $L_a = 0.0587$ H, $K_e = 0.1485$ V/(rad/sec.), $J=0.0455 \times 10^{-3}$ Kg·m², $B_m = 0.0948 \times 10^{-3}$ Nm/(rad/sec).

The simulation was carried out for a load torque equal to zero. The results are shown in Fig. 9, where the PMDC motor speed, the armature current (the same TEG current) and the TEG voltage are shown. It was observed that the TEG is operating near the open circuit voltage; so, this shows the need to study and implement maximum power point control methods.

II. Photovoltaic maximum power point control

Photovoltaic modules can operate at one maximum power point (MPP), this is an optimal voltage and an optimal current where the PVM supplies the maximum power to the connected load. Therefore, an essential part of PV systems is a kind of control called maximum power point tracker (MPPT), whose main function is to attempt to keep the PV array operating at the MPP [11].

A MPPT must perform two tasks: first, to find the maximum power point, and second to keep the PVM operation in that point. Many methods have been proposed in order to find the MPP; in this case the Linear Reoriented Coordinates Method (LRCM) [12], which estimates the optimal voltage V_{ap} , was implemented in the PVM block diagram in Saber. So, the terminal called V_{ap} can be used as the setpoint for a controller.

The second task is developed by a dc-dc power converter connected to the PV array, and by a controller. The last one adjusts the power converter duty ratio until the PVM output voltage equals to the optimal voltage V_{ap} .

The scheme implemented in Saber is shown in Fig. 10. This scheme consisted of a PVM SX-10M, a coupling capacitor C_l , a buck-boost converter and a control loop. The integrator has a gain K and its output is compared with a triangular signal to generate the pulse width modulated (PWM) signal. This signal manages the buck-boost switch.

The Saber simulation was carried out for irradiance levels of 600W/m² during 35ms, then the irradiance is increased up to 1000W/m², and from 65ms to final time the irradiance was 800W/m². The results with $K=10$ are shown in Fig. 11, where is shown the PVM power, the voltage and the current with the MPPT. For all irradiance levels the PVM is operating near to the MPP, the results are summarized in the table I.

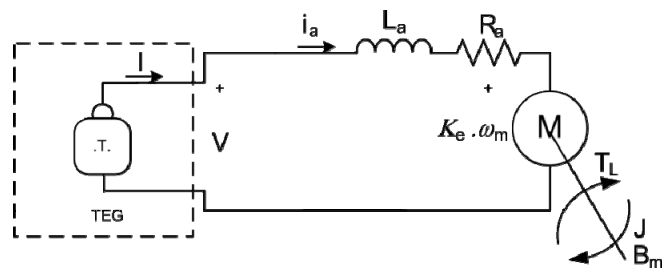

FIGURE 7
A PMDC MOTOR DIRECTLY COUPLED TO A TEG

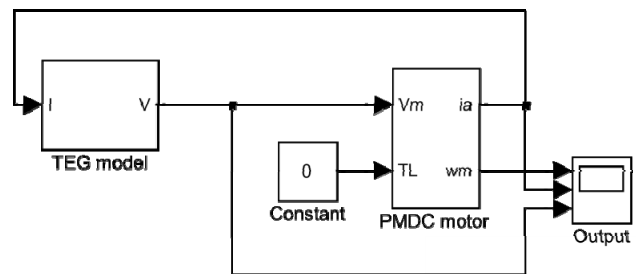

FIGURE 8
SIMULATION OF THE TEG FEEDING A PMDC MOTOR

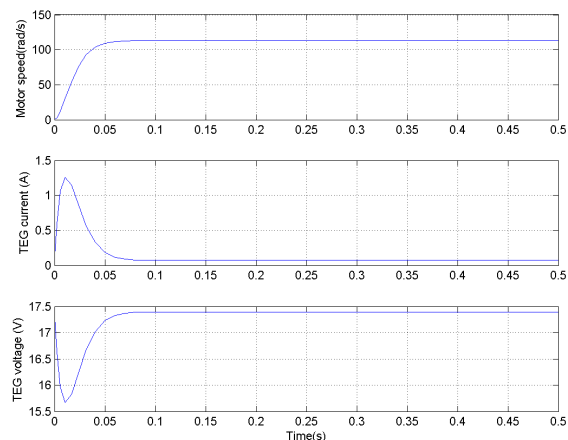

FIGURE 9
SIMULATION RESULTS FOR TEG FEEDING A PMDC MOTOR

TABLE I
SUMMARY RESULTS POINT

Irradiance [W/m ²]	PVM power in MPP [W]	PVM power with Control [W]
600	5.85	5.6
800	8.06	7.6
100	10.42	9.69

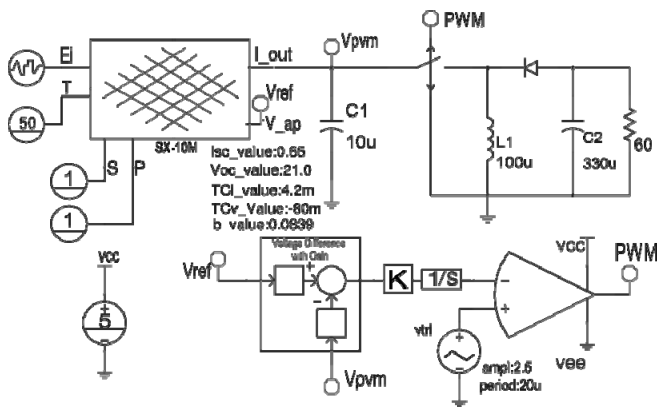

FIGURE 10
SABER SCHEMATIC OF MPPT

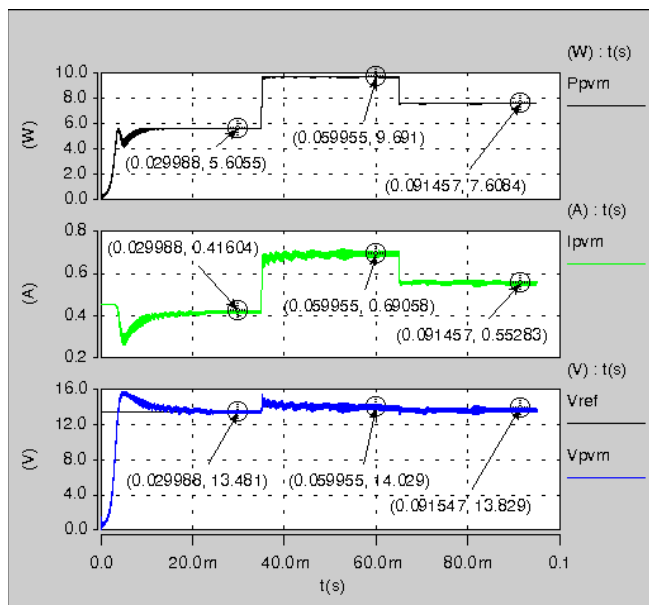

FIGURE 11
PVM POWER, CURRENT AND VOLTAGE WITH MPPT

III. Finding the optimal duty ratio of an open loop system with a Fuel Cell and a Step-Down DC/DC converter

An easy way to determine the optimal duty ratio for a specific load is to vary the pulse width which controls the power converter input current. Fig. 12 shows an example using Simulink of how the fuel cell model described in section II can be implemented with a step-down DC-DC converter. The results could be plotted in an X-Y graph as is shown in Figure 13. The student can visualize the duty ratio values for which the fuel cells give the maximum power to the load.

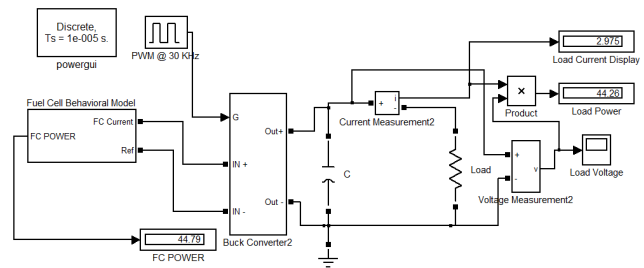

FIGURE 12
SIMULINK MODEL OF FUEL CELL AND BUCK CONVERTER

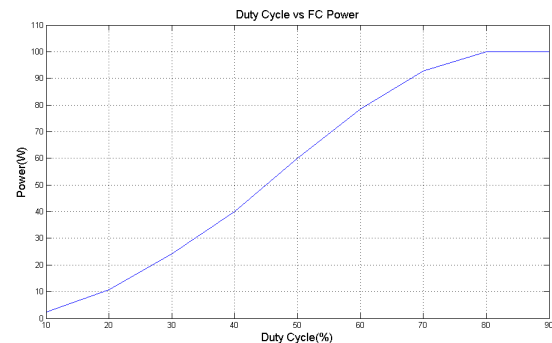

FIGURE 13
SABER SCHEMATIC OF MPPT

EXPERIENCE ASSESSMENT

All of the models and applications presented above have been used to draw student's interest in the field of renewable energy sources. These models have been used both in electrical engineering courses and research experience in the University of Puerto Rico, Mayaguez Campus.

These experiences began in the fall of 2006 with one electrical engineering (E.E.) undergraduate student; nowadays, the research team consisted of 12 E.E. undergraduate students, 3 computer engineering (Cp.E) undergraduate students and 6 (E.E.) graduate students. Table II summarizes the number of research students from 2006 to 2009. Almost the 40 % of the undergraduate students that had begun a research experience in senior year have initiated their graduate studies.

As a result of the research experience, the graduate and undergraduate students have published six peer review paper. All of these publications use the models described above, including the history of the fuel cells, a general purpose tools for simulating the behavior of PVM's and different control strategies for PV systems.

In fall 2009 a new course called Alternative Power Generation (INEL 4417) is going to be available, and the course called Power Electronics Applied to Renewable Energy (INEL54XX) is in preparation. These courses are a response to the high demand and the need for qualifying engineers to face today's energy challenges.

TABLE II
NUMBER OF ENROLLED STUDENTS

	E.E	Cp.E.	Grad
Fall 06	1	0	0
Spring 07	3	1	2
Fall 07	4	2	3
Spring 08	6	2	4
Fall 08	8	2	5
Spring 09	12	3	6

Additionally, students have commented that the research experience improved their background in alternative energy sources, as well as, their oral and written communication skills [13]. Moreover, students that applied circuit analysis and control theory on the presented models took the fundamental courses of electrical engineering with more enthusiasm.

CONCLUSIONS

Small renewable energy systems were described in this article. These systems are the basis for future research projects in this area. Also, they were very useful to analyze the behavior of each renewable energy source, as well as to determine the conditions for operation at maximum power.

The thermoelectric generator model based on the electrical characteristics can be used for steady-state analysis or transient analysis. This paper showed the application of TEG model to improve the understandings of state space modeling; a PMDC motor directly coupling to a TEG were modeled and simulated.

Simulation and analysis of electric circuits using renewable sources of energy, allow undergraduate students to take part in research projects. These projects involve formulation of new mathematical models to describe behavior of renewable sources of energy, as well as, design and implementation of maximum power point tracking controllers, and design and implementation of DC-DC conversion systems.

Undergraduate students can find different applications within the study of the renewable source of energy behavior. These applications are a junction between different engineering areas involving electrical circuit analysis, control and power analysis, as well as mechanical and material science.

The research culture generated with the studies of the models presented in this article, have enabled to the ECE undergraduate students at UPRM to create new research perspectives encouraging to publish their works and to follow their research process in a graduate level.

ACKNOWLEDGMENT

The authors gratefully acknowledge the contributions of all the members that belong to the Mathematical Modeling and Control of Renewable Energies for Advance Technology & Education (M_{inds}² CREATE) Research Team at UPRM. Special thanks to all undergraduate students who made part of this study.

REFERENCES

- [1] Energy Information Administration, "Greenhouse Gases, Climate Change, and Energy", <http://www.eia.doe.gov/bookshelf/brochures/greenhouse/Chapter1.htm> Accessed: 19 March 2009.
- [2] National Renewable Energy Laboratory, "Learning About Renewable Energy" <http://www.nrel.gov/learning/> Accessed: 19 January 2009.
- [3] Kim, R.-Y. , 2008. "Aggregated modeling and control of a boost-buck cascade converter for maximum power point tracking of a thermoelectric generator", *Applied Power Electron. Conf. and Exp. APEC. IEEE*, pp. 1754–1760.
- [4] Findley, K., Green, K. , Brown, G. and Bahr, D. 2007. "Re-evaluating the Objectives for Undergraduate Research", *Frontiers in education conference - global engineering: knowledge without borders, opportunities without passports, 2007. FIE '07. 37th annual*, pp. F1D-18-F1D-23.
- [5] Jimenez M. and Santiago, N. , 2005. "The supporting role of CAD/CAM tools in undergraduate research education in electrical and computer engineering", *Information Technology Based Higher Education and Training, 2005. ITHET 2005. 6th International Conference on*, pp. S3C/23-S3C/26.
- [6] Rivera E. and Rodriguez L. , 2007. "The z-source converter as an introduction to power electronics and undergraduate research", *Frontiers in education conference - global engineering: knowledge without borders, opportunities without passports, 2007. FIE '07. 37th annual*, pp. T2C-5-T2C-10.
- [7] Ortiz-Rivera E. and Peng, F. , 2005. "Analytical Model for a Photovoltaic Module using the Electrical Characteristics provided by the Manufacturer Data Sheet", *Power Electronics Specialists Conf., 2005. PESC '05. IEEE 36th*, pp. 2087-2091.
- [8] Ortiz-Rivera, E. I., Pan, Z. and Wang, J. , 2008. "A mathematical model to describe the electrical characteristics for a fuel cell", *Power Electronics Specialists Conf., 2008. PESC 2008. IEEE*, pp. 559-561.
- [9] Chu, R. C. , Kadotani, K., Shintani, T., Tanimura, T., Hatanaka, T. *et al* , 2003. "Thermoelectric generator utilizing boiling-condensation (experiment and modeling)", *Thermoelectrics, 22nd International Conf. on - ICT*, pp. 546-549.
- [10] Gil-Arias O. and Ortiz-Rivera, E. I., 2008. "A general purpose tool for simulating the behavior of PV solar cells, modules and arrays", *Control and Modeling for Power Electronics, 2008. COMPEL 2008. 11th Workshop on*, pp. 1-5.
- [11] Ropp, M., "Photovoltaic Systems" In Capehart (ed.) 2007. *Encyclopedia of Energy Engineering and Technology*, CRCPress: Taylor and Francis Group, LLC, pp. 1147-1159.
- [12] Ortiz Rivera, E. and Peng, F. 2006. "Linear Reoriented Coordinates Method", *Electro/information Technology, 2006 IEEE International Conference on*, pp. 459-464
- [13] Ortiz-Rivera E. I., Reyes-Hernandez A.L.; Febo, R.A. "Understanding the History of the Fuel Cells" 2007 IEEE Conference on the History of Electric Power.

AUTHOR INFORMATION

Eduardo I. Ortiz-Rivera, is Assistant Professor at University of Puerto Rico-Mayaguez, eortiz@ece.uprm.edu

Jesus Gonzalez-Llorente, is graduate student at University of Puerto Rico-Mayaguez, jesus.gonzalez@ece.uprm.edu

Andres Salazar-Llinas, is graduate student at University of Puerto Rico-Mayaguez, Andres.salazar@ece.uprm.edu