

Proposed System Model and Simulation for Three Phase Induction Motor Operation with Single PV Panel

Eliud Ortiz-Perez, Ricardo Maldonado, Harry O'Neill, Eduardo I. Ortiz-Rivera (IEEE member)

University of Puerto Rico, Mayagüez Campus
Computer and Electrical Engineering Department

Abstract— The main objective of this paper is the design and integration of a series of power electronics converters in order to make an induction motor work with a single photovoltaic panel as efficiently as possible. The power electronics converters that we intend to design are a Buck-Boost Converter and a Pulse Width Modulation (PWM) Three-Phase Inverter. The integration of a Maximum Power Point Tracker (MPPT) is also discussed. Each of these converters has its own purpose; the Buck-Boost Converter will keep a constant and steady DC output from the photovoltaic panel. The Three-Phase Inverter will change the DC output from the Buck-Boost Converter to an Alternate Current that the induction motor can use. In order to integrate the power electronic converters into the system, research has to be done in order to understand the complexity of this work; this paper will also help us to keep in mind the benefits that this kind of research can bring to the World's crisis of the global warming.

I. INTRODUCTION

Global warming is a known problem that affects the entire World [1]; Carbon dioxide emissions from vehicles and power plants are affecting the global temperature and climate. For years, scientists and researchers have done research and investigations in order to come up with new ideas and proposal to reduce the imminent threat from the CO₂ emissions. Renewable energy systems are a source of clean energy and for that reason it is one of the most popular solutions to reduce the CO₂ emissions [1]. The problem with some renewable energy systems is that the energy that they produce is in Direct Current (DC) form and most appliances work with Alternate Current (AC). That is when the power electronics come into play by designing and developing converters and inverters that can amplify and change that energy from one type to the type that we need. This paper proposes the implementation of a single photovoltaic panel as a renewable energy source to operate an induction motor.

The objective of the paper is to design a PV system to power a small induction motor. The system should be optimized to extract the maximum power from the PV panel and use that power as efficiently as possible in the motor. Figure 1 shows a general layout of the project components. The crucial parts of the design are the DC-DC Converter, the MPPT method that will keep the optimal power on the output, and the inverter that will change the power from DC

to AC. The DC-DC converter that is discussed is the Buck-Boost topology and the inverter is a PWM Unipolar Three Phase Inverter. There are several methods used for MPPT. [2] lists 19 different methods found on the subject of MPPT. Some of these methods are: Perturb and Observe, Incremental Conductance, Fractional Open-Circuit Voltage, Fractional Short-Circuit Current, Fuzzy Logic Control, Ripple Correlation Control (RCC), etc. In this paper the Perturb and Observe method will be used with the PV exponential model [10]. Through out the paper the different components and their respective models are discussed.

II. METHODOLOGY

A. Design Specifications

Figure 1 shows the general layout of the system to be built. A single photovoltaic panel will be used to power a three phase induction motor. The induction motor will be rated at 0.2 hp. This means that the system must be designed to handle approximately 200W of power. The control system should be able to extract the maximum power output from the PV panel using a MPPT algorithm. The system should work without a battery backup. The DC-DC converter to be used will be a Buck-Boost converter. An unipolar PWM inverter will be used to supply power and control the efficiency of the induction motor. The system will be optimized to extract the maximum power from the PV panel and optimize the power usage by the induction motor.

B. Solar Panel Model

The exponential model will be used to describe and predict the behavior of the photovoltaic panel. The current is given by (1):

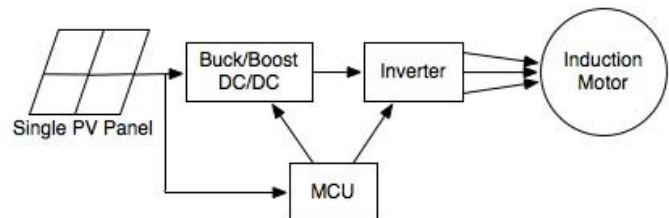

Figure 1 Generalized Project Design

$$I(V) = \frac{I_{sc}}{1 - \exp\left(\frac{-1}{b}\right)} \cdot \left[1 - \exp\left(\frac{V}{b \cdot V_{oc}} - \frac{1}{b}\right)\right] \quad (1)$$

I_{sc} is the short circuit current and V_{oc} is the open circuit voltage. Multiplying (1) by the voltage we get the equation for Power (2),

$$P(V) = \frac{V \cdot I_{sc}}{1 - \exp\left(\frac{-1}{b}\right)} \cdot \left[1 - \exp\left(\frac{V}{b \cdot V_{oc}} - \frac{1}{b}\right)\right] \quad (2)$$

The maximum power will be obtained when the panel works at its optimal voltage (V_{op}). The optimal current (I_{op}) can be obtained by substituting V_{op} in (1). By substituting these optimal values in (2) we obtain (3),

$$P_{max} = \frac{V_{op} \cdot I_{sc}}{1 - \exp\left(\frac{-1}{b}\right)} \cdot \left[1 - \exp\left(\frac{V_{op}}{b \cdot V_{oc}} - \frac{1}{b}\right)\right] \quad (3)$$

Solving (3) for b can be approximated to be (4),

$$b \cong \frac{\left(\frac{V_{op}}{V_{oc}} - 1\right)}{\ln\left[1 - \frac{P_{max}}{V_{op} \cdot I_{sc}}\right]} \quad (4)$$

This value is distinct for every solar panel. Thus value of b can be obtained by measuring V_{oc} and I_{sc} , for the particular solar panel. With the values of V_{oc} , I_{sc} and b for the panel, an accurate representation of the voltage and current characteristics of the panel can be obtained using the exponential model. As an example, the current and voltage characteristics of a PowerUp BSP-512 solar panel were measured by varying the load resistance applied to the panel. This panel is the last from left to right on the top row of figure 2. The panel temperature was at 57.8°C . Locating the point of maximum power from the table and substituting the values into (4), b was found to be approximately 0.107075. This value can now be substituted in (1) and (2) to obtain the current, voltage and power characteristics of the panel through the exponential model. Figure 3 and Figure 4 compare the measured current-voltage and power-voltage characteristics, respectively, of the panel to those obtained from the exponential model.

C. DC-DC Topology: Buck-Boost Converter

To achieve maximum power point tracking of the photovoltaic panel, the Buck-Boost DC-DC converter will be used. (5) describes the dynamic model of a buck boost converter with s being the state of the transistor (0 for OFF and 1 for ON). Based on the dynamic model the transfer function in steady state is shown in (6) where D is the duty cycle, V_o is the load voltage and V_i is the power source voltage.

$$\begin{bmatrix} \frac{dI_L}{dt} \\ \frac{dV_C}{dt} \end{bmatrix} = \begin{bmatrix} 0 & \frac{1-s}{L} \\ \frac{s-1}{C} & \frac{-1}{RC} \end{bmatrix} \begin{bmatrix} I_L \\ V_C \end{bmatrix} + \begin{bmatrix} \frac{E}{L} \\ 0 \end{bmatrix} (s) \quad (5)$$

$$\frac{V_o}{V_i} = \frac{-D}{1-D} \quad (6)$$

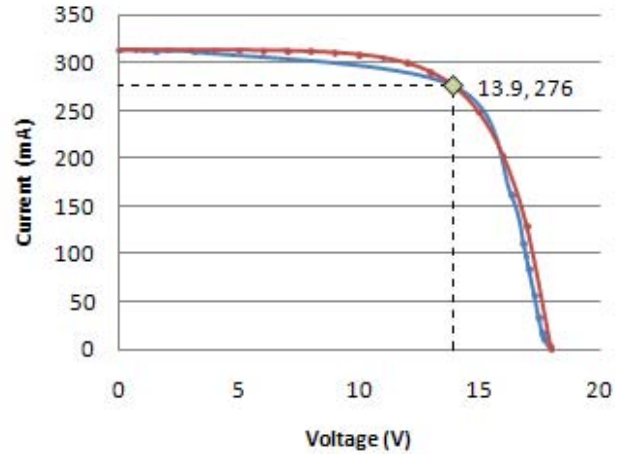

Figure 2. Current-Voltage PV Characteristics

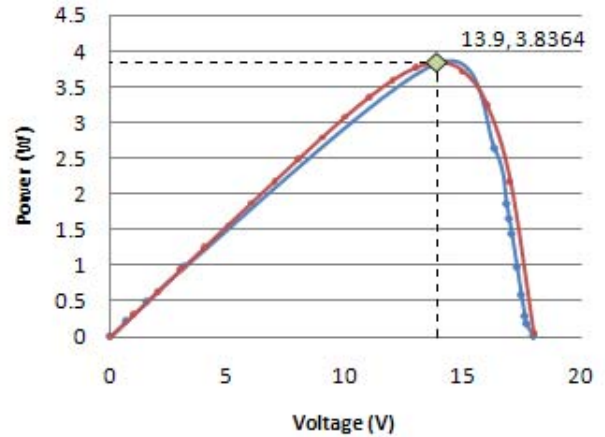

Figure 3. Power-Voltage PV Characteristics

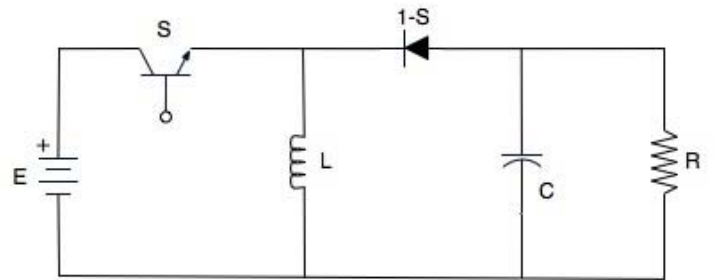

Figure 4. Basic Buck-Boost Configuration

This converter can lower the input voltage with duty cycles less than 50% and increase it with higher ones. The converter consists mainly of an inductor for energy transfer, a capacitor to maintain a constant voltage at the output, a transistor switch (MOSFET) and a power diode.

D. PWM Three Phase Inverter

The Six Step Inverter and the PWM Three-Phase Inverter are the two topologies that are appropriate for the proposed three-phase system. The proposed inverter is the PWM Three Phase Inverter, since it is the same topology of the six step inverter but only with a PWM applied to it. When the PWM is applied to the Six Step Inverter, the shape of the output waveform is kept so that the third harmonic is cancel along with its multiples. An advantage of PWM switching is a reduced filter requirement for harmonic reduction and the controllability of the fundamental frequency amplitude.[11] This is why the PWM Three-Phase Inverter is the one that is going to be implemented on the system. Each pair of switches have its own sinusoidal reference wave, so there will be three reference waves with 120° apart from each other producing a balance three phase output. Each switch is controlled by comparing the reference wave to a triangular wave. The switching control is the following:

$$S_1 \text{ is on when } V_A > V_{tri} \quad S_4 \text{ is on when } V_A > V_{tri}$$

$$S_2 \text{ is on when } V_C > V_{tri} \quad S_5 \text{ is on when } V_C > V_{tri}$$

$$S_3 \text{ is on when } V_B > V_{tri} \quad S_6 \text{ is on when } V_B > V_{tri}$$

Also by choosing an odd triple multiple of the reference frequency as the carrier frequency, the harmonics will be minimized [11].

E. Inductor Motor Model

[12] shows the model of the induction motor used for the system simulation. The model is a completely electrical representation of a 3 phase induction motor which includes the mechanical aspects of the motor. The parameters for the model were obtained by performing a locked rotor and no load tests on an induction motor. The model was tested and the torque vs speed characteristics appear in Figure 7. The torque ripples and then stabilizes. Finally, the torque starts falling when the motor reaches the synchronous speed.

F. Maximum Power Point Tracking

The amount of electrical power generated by a PV system depends on solar irradiance and weather conditions affecting the area where the PV panels are installed. The current and voltage at which a PV module generates the maximum power is known as the maximum power point. Maintaining the PV module electricity generation at its maximum power is called maximum power point tracking, MPPT.

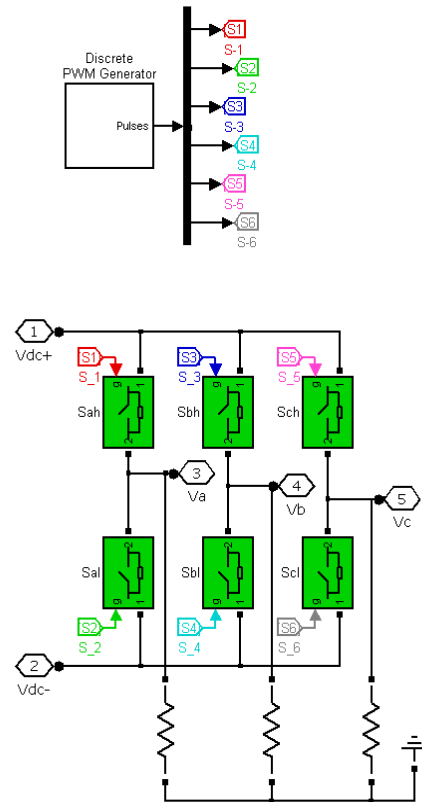

Figure 5. Simulation of a PWM Three-Phase Inverter.

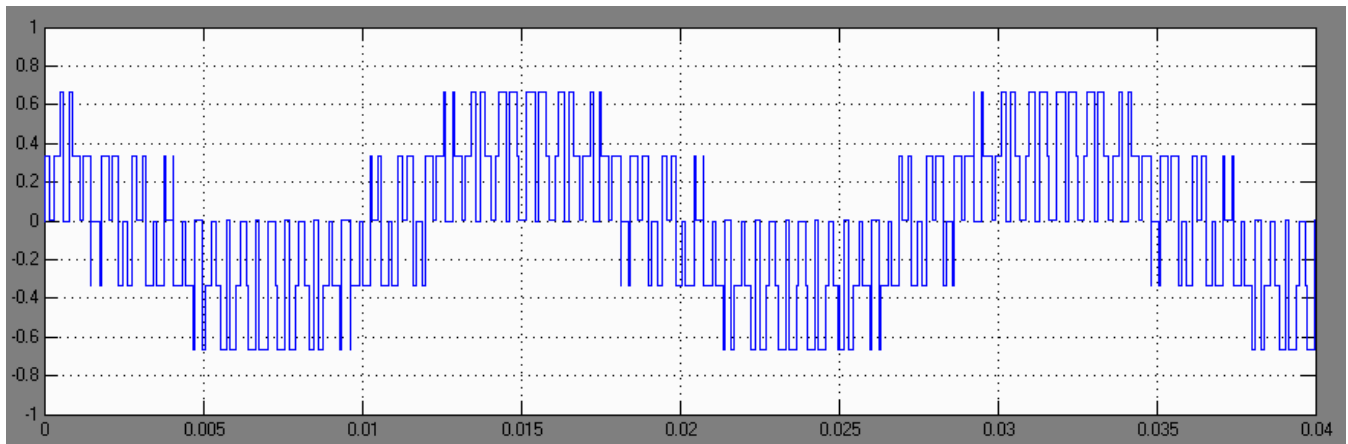

Figure 6. Output of a 3phase Unipolar PWM inverter.

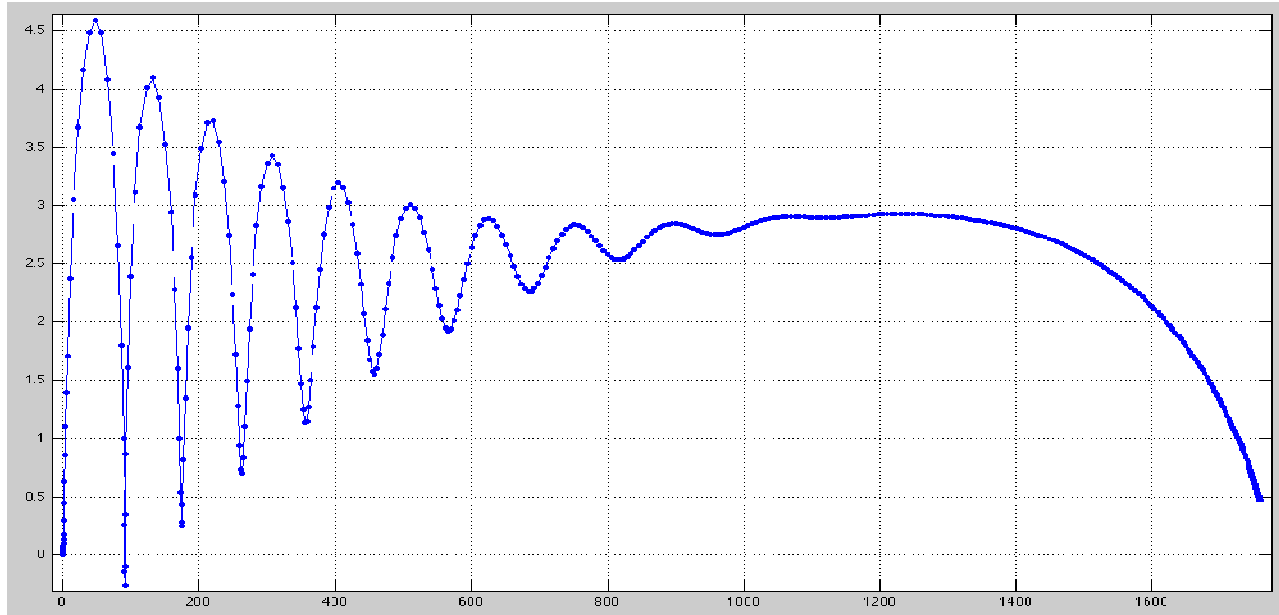

Figure 7 Torque vs Speed

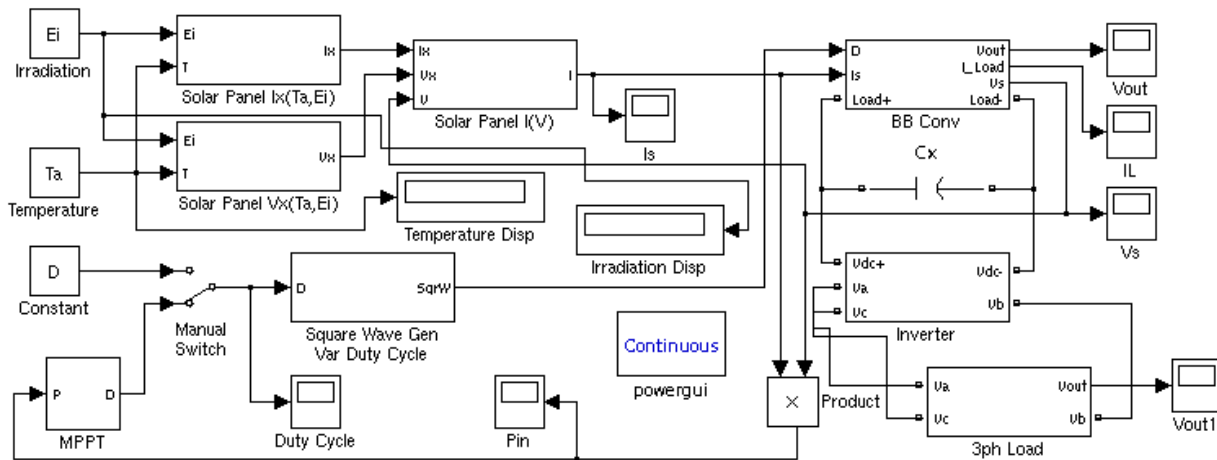

Figure 8. Top level simulation diagram

MPPT modifies the electrical operating point of a PV system. This means that the operating voltage of the PV system will be moved, i.e., changed; this can be accomplished through the use of a shunt resistor or pulse width modulation, PWM. The voltage is changed and measured; the corresponding current is measured. The process continues until the value where the maximum power is produced is found. MPPT improves the electrical efficiency of a PV system by continuously extracting the maximum power, thus reducing the number of solar panels or arrays required to generate a desired output.

The maximum power from a PV panel can be extracted using a MPPT algorithm. The first algorithm to be tested will be perturb and observe. Basically, the controller will periodically increment or decrement the PV panel voltage and adjust the voltage in the direction that yields the higher power output from the PV; this algorithm is better known as

the hill climbing method. The hill climbing method will be compared to the optimal duty ratio method proposed in [4].

G. System Simulation

Using the previously mentioned solar panel model, buck-boost converter, and PWM three phase inverter, we simulated the response of the proposed system. The SIMULINK model seen in Figure 8 was used where all the subsystems correspond to the proposed individual models. The result of the simulation can be seen in Figures 9-14.

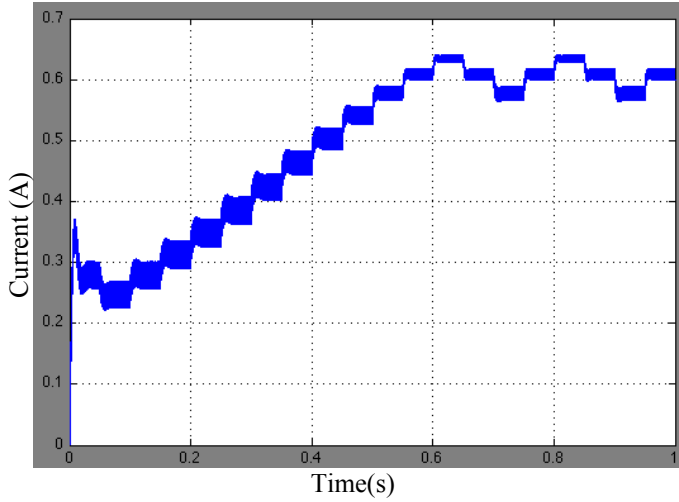

Figure 9. Solar Panel Current

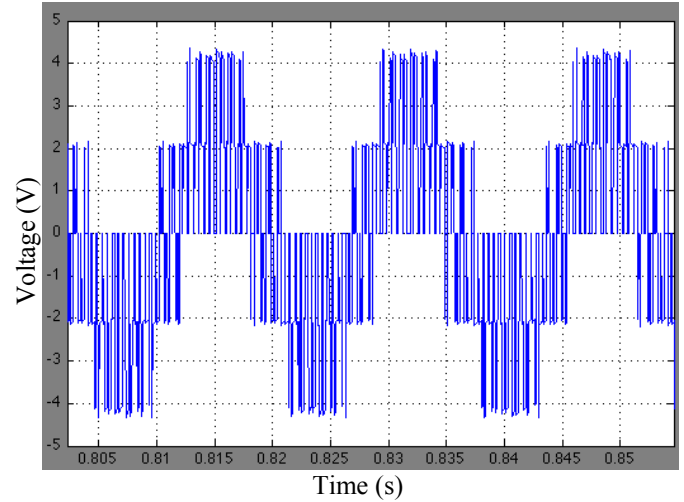

Figure 12. Voltage of one phase of the load

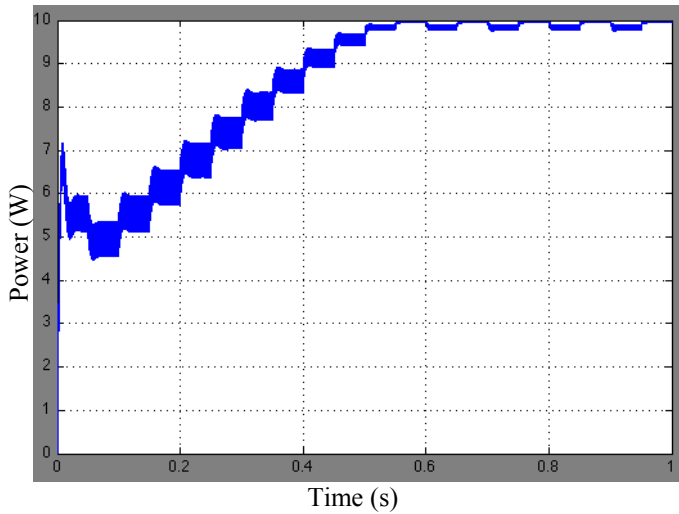

Figure 10. Solar Panel Power

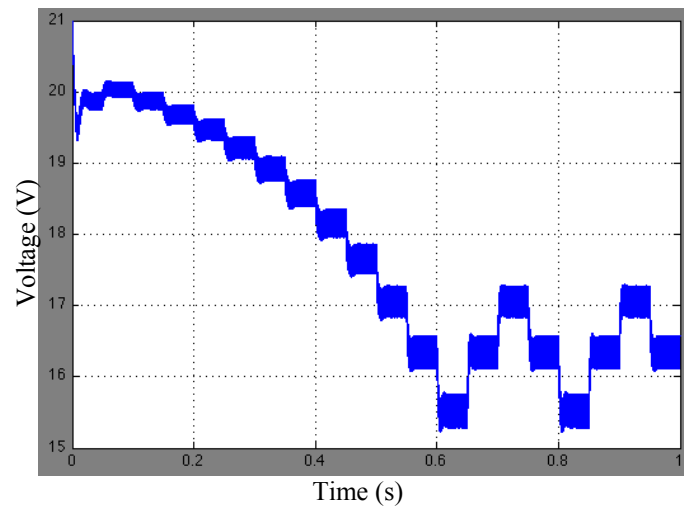

Figure 13. Solar Panel Voltage

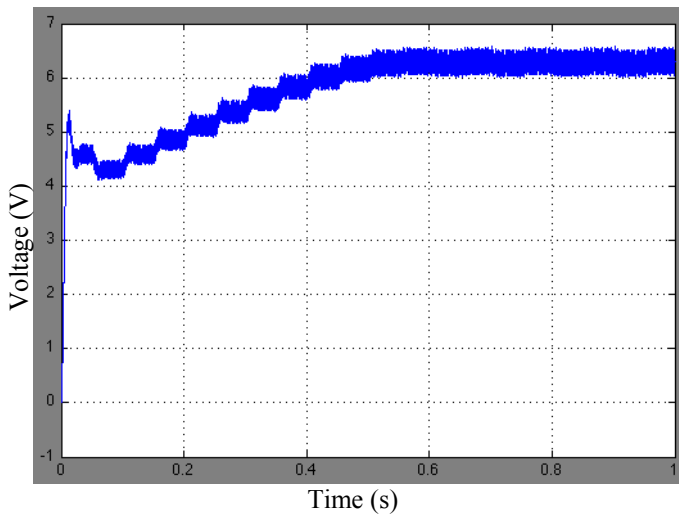

Figure 11. Buck-Boost Output Voltage

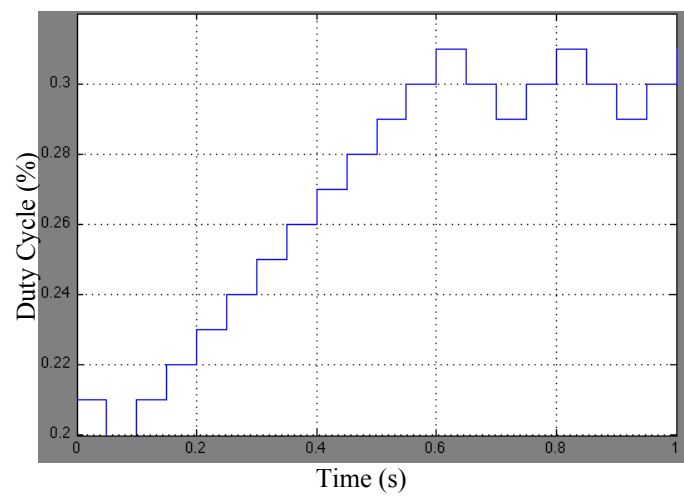

Figure 14. Duty Cycle

III. CONCLUSION

Using a dc-dc converter (buck-boost topology) for maximum power point tracking of a solar panel and a 3 phase full-bridge PWM inverter for motor control, we expect to use at least 80% of the available power given by the single solar panel. A microcontroller (or two) will be used to implement the control algorithms for MPPT and motor control. This solution seems to be a cost effective one, since using good components for the topologies, a low-cost low-power microcontroller and good algorithms, will lower the manufacturing and operation costs of the system. The proposed system will be compared with a similar one containing a second DC-DC conversion stage, a transformer or both in search of greater efficiency. Greater efficiency means that more work can be done with the same power source (solar panel) and motor, which we believe would be the most expensive components in this system. Therefore, greater efficiency can be translated in a lower cost.

REFERENCES

- [1] S. Pal, "Wind Energy — An Innovative Solution To Global Warming?" *Developments Renewable Energy Technology (Icdret), 2009 1st Int. Conf.*, pp. 1–3, Dec. 2009.
- [2] Esram, T.; Chapman, P.L.; *Energy Conversion, IEEE Transactions on* Volume: 22, Issue: 2 Digital Object Identifier: 10.1109/TEC.2006.874230 Publication Year: 2007 , Page(s): 439-49
- [3] O. Gil-Arias, IEEE Student Member & E.I. Ortiz-Rivera, Member IEEE, "A General Purpose Tool for Simulating the Behavior of PV Solar Cells, Modules and Arrays," *IEEE Conf. Journal on PV Solar Cells*, pp. 1–5, Aug. 2008.
- [4] E.I. Ortiz-Rivera, Member IEEE, "Maximum Power Point Tracking using the Optimal Duty Ratio for DC-DC Converters and Load Matching in Photovoltaic Applications," *IEEE Conf. Journal on Photovoltaic Applications* pp. 987–991, Feb. 2008.
- [5] Jimenez-Brea, E.; Salazar-Llinas, A. ; Ortiz-Rivera, E. ; Gonzalez-Llorente, J. "A Maximum Power Point Tracker Implementation for Photovoltaic Cells Using Dynamic Optimal Voltage Tracking," *Applied Power Electronics Conference and Exposition (APEC), 2010 Twenty-Fifth Annual IEEE*, pp. 2161-2165.
- [6] S. Halasz, G. Csonka, A.A.M. Hassan, B.T. Huu, "Analysis of the unipolar PWM technique", *Electromechanical Conference, 1996. Melecon '96, 8th Mediterranean*, 13-16 May 1996, Volume, pag. 353-356.
- [7] Jiménez-Toribio, E.E.; Labour-Castro, A.A.; Muñoz-Rodríguez, F.; Pérez-Hernández, H. R.; Ortiz-Rivera, E.I.; "Sensorless Control of SEPIC and Ćuk Converters for DC Motors using Solar Panels," *Electric Machines and Drives Conference, 2009. IEMDC '09. IEEE International*, pp. 1503-1510.
- [8] Jimenez, E.; Ortiz-Rivera, E.I.; Gil-Arias, O. ; "A dynamic maximum power point tracker using sliding mode control," *Control and Modeling for Power Electronics, 2008. COMPEL 2008. 11th Workshop on* , vol., no., pp.1-5, 17-20 Aug. 2008
- [9] Armstrong, S.; Hurley, W.G.; Self-regulating maximum power point tracking for solar energy systems *Universities Power Engineering Conference, 2004. UPEC 2004. 39th International* Volume: 2
- [10] Ortiz-Rivera, E.I. ; Peng, F.Z. ; "Analytical Model for a Photovoltaic Module using the Electrical Characteristics provided by the Manufacturer Data Sheet"
- [11] D. Hart, 1997, "Power Electronics", Prentice Hall, Inc
- [12] [Diaz, A.; Saltares, R.; Rodriguez, C.; Nunez, R.F.; Ortiz-Rivera, E.I.; Gonzalez-Llorente, J.; "Induction Motor Equivalent Circuit for Dynamic Simulation," *Electric Machines and Drives Conference, 2009. IEMDC '09. IEEE International* , pp. 858-863.